

# GC-100 Network Adapter

## Add Any Device to a Network in Minutes

Global Caché's GC-100 family of Network Adapters connects almost any piece of electronic equipment to a network so that it can be accessed, controlled, and maintained from anywhere over a network or the Internet. Our Network Adapters employ a unique and transparent architecture that is engineered to seamlessly integrate with all types of control, automation, and monitoring environments. Compact and economical, they provide a quick, simple and cost-effective way to bring the advantages of device networking to homes, educational institutions, businesses, and houses of worship.

### GC-100 Models

#### GC-100-06

- Power input
- Network connection
- Serial port
- Three independent IR outputs or sensor inputs
- Dimensions: 6.0" L x 3.0" D x 1.3" H

#### GC-100-12

- Power input
- Network connection
- Two serial ports
- Three relay connections
- Six independent IR outputs or sensor inputs
- Dimensions: 12.0" L x 3.0" D x 1.3" H

#### GC-100-18

- Same configuration as GC-100-12
- Dimensions: 17.5.0" L x 3.0" D x 1.3" H

#### GC-100-18R

- Same configuration as GC-100-18 with rack mount kit installed
- 1U rack height



### Key Features

- Network virtually any device in minutes
- Connects infrared (IR) devices to a TCP/IP network
- Connects RS232, Sony Control-S devices, and sensors to a TCP/IP network
- Connects contact closure (relay) devices to a TCP/IP network
- Works well with wireless
- Low profile, stylish enclosure
- Peripheral equipment includes IR learning and IR input over a TCP/IP network
- Available in 3 sizes with a 19" rack mount version
- Silent, fan-free, environmentally friendly RoHS compliant

# Technical Specifications

## Power Input

- 9 to 18V DC@300mA (wall power adapter included)
- International 220V available

## LED indicators

- Power
- Network activity
- Link status
- IR transmission
- Sensor input state
- GC-100 visual ID

## Setup

- Integrated web server for easy configuration
- Configure through TCP/IP set up commands

## Discovery & Setup Utility

- Included Windows-based software simplifies GC-100 network discovery of units and setup

## Network Interface

- Connector: RJ45
- Protocol: 10 Base-T Ethernet
- Standards: TCP, DHCP, HTTP

## Serial Interface

- Connector: Male DB9
- Data Rates: 1200 baud to 57.6 Kbaud
- Parity: odd, even, none
- Flow control: bi-directional hardware RTS/CTS
- IR input: utilizing a GC-IRE and GC-RG1, IR commands are received via RS232 port.

## IR & Sensor Interface

- Connector: 3.5mm stereo jack
- Selectable IR outputs or sensor inputs per port
- IR input: IR commands received via RS232 port utilizing GC-IRE and GC-RG1
- IR emitter supplied for each IR port

## Relay Interface

- Connector: screw terminal plug, 24V AC/DC@.5A, N.O. contact with transient voltage suppression
- Capability: contact closures

## Certifications

- FCC (Part 15, Class B), C-tick, CE
- RoHs compliant

## Software

- Product GC-IRL Learner Utility
- Development and Testing GC-100 Test Utility GC-CCF Conversion Utility GC-Scan Test Utility IR Test Utility

## Warranty

- One year limited warranty

# Connect Devices to a Network with a GC-100

## GC-100-12

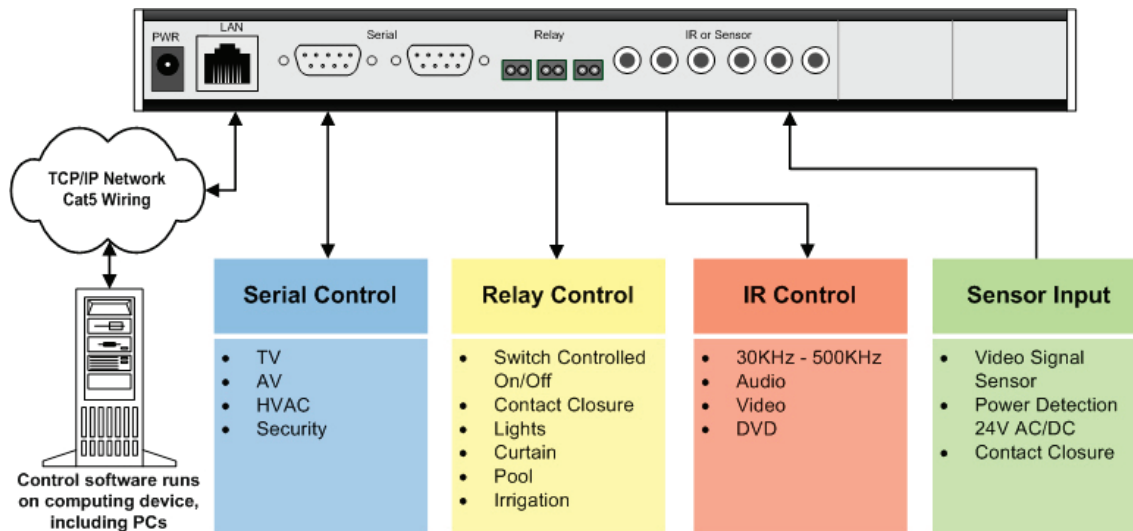

**Global Caché**

**Corporate Headquarters:**

160 East California Street

PO Box 1659

Jacksonville, Oregon 97530 U.S.A.

Telephone: 541-899-4800

Fax: 541-899-4808

[www.globalcache.com](http://www.globalcache.com) - [info@globalcache.com](mailto:info@globalcache.com)

